

WALL MOUNTED 9, 12, 15,000 BTUh SYSTEMS

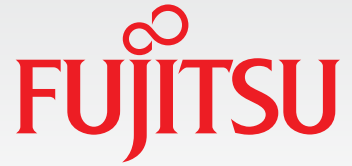

SYSTEMS 9LZAS1, 12LZAS1, 15LZAS1

SYSTEMS 9LZAH1, 12LZAH1, 15LZAH1



SLIM & STYLISH DESIGN

Best in class, feature packed, inverter heat pump system with new slim wall-mounted system and improved fan design. 1-3/16in. (30mm) thinner than the RLS3Y model.

HIGH EFFICIENCY

These top of the line, high efficiency systems feature a state of the art heat transfer system design with increased fan performance. Experience considerable energy savings with up to 30% reduction in energy consumption.

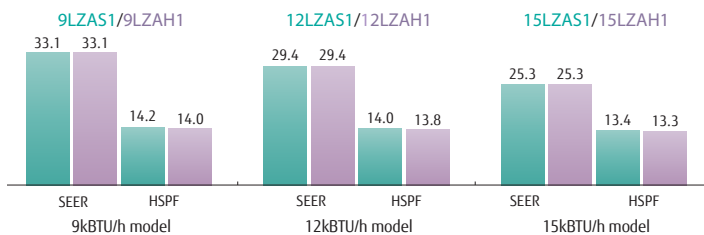

High efficiency DC Fan motor



DC Rotary compressor



Ø 3/16in. (5mm) Hi-density heat exchanger



Ø 1/4in. (7mm) Large heat exchanger



Ø3-3/4in. (95mm)

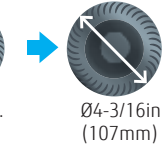

Large cross-flow fan: With the large-diameter fan, efficient air volume can be obtained at low power.

THIRD PARTY THERMOSTAT CONVERTER (OPTIONAL)

UTY-TTRX

Control your Fujitsu heating and cooling system with your favorite smart thermostat (not included).

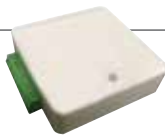

SMART DEVICE CONTROL

Built-in Wi-Fi capability allows the LZAS series to be controlled from anywhere using the FGLair app on a smart device, with no loss of system efficiency. (FGLair app is available for download on the Apple App store and Google Play Store.)



BASE PAN HEATER (XLTH MODELS ONLY)

The LZAH1 unit comes equipped with a base pan heater that provides sufficient heating even at extremely low outdoor temperatures. When outdoor temperature falls to 36°F or below, the base pan heater is activated in order to prevent condensation from freezing. Without a heater, freezing condensate can cause noise and damage to the fan blades, condenser, and overall system performance.



XLTH with base heater

Without base heater



← Base pan showing heater and drain holes

ENERGY SAVING PROGRAM (ESP) FUNCTION





With the ESP function, the LZAS system actively monitors occupancy and adjusts system settings accordingly to achieve optimum energy savings. Once the system detects an occupant, the settings are reverted to the user defined settings in order to maintain comfort.



Use voice control for your Fujitsu LZAS system through Amazon Echo or Google Home.



OPTIONAL ACCESSORIES

Wired Remote Controller: UTY-RNRUZ2 	Simple Remote Controller: UTY-RSRY / UTY-RHRY 	Communication Kit: UTY-TWRXZ2 	External Input and Output PCB: UTY-XCSXZ1 	Thermostat Converter: UTY-TTRX 
--------------------------------------------------------------------------------------------------------------------------	------------------------------------------------------------------------------------------------------------------------------------	--------------------------------------------------------------------------------------------------------------------	----------------------------------------------------------------------------------------------------------------------------------	-----------------------------------------------------------------------------------------------------------------------

SPECIFICATIONS

Model Name	Indoor Unit		ASUG09LZAS	ASUG12LZAS	ASUG15LZAS	ASUG09LZAS	ASUG12LZAS	ASUG15LZAS	
	Outdoor Unit		AOUG09LZAS1	AOUG12LZAS1	AOUG15LZAS1	AOUG09LZAH1	AOUG12LZAH1	AOUG15LZAH1	
Power Source	V / Ø / Hz		208/230 V / 1Ø / 60Hz			208/230 V / 1Ø / 60Hz			
Capacity	Cooling	BTU/h (Min.-Max.)	9,000 (3,100-12,000)	12,000 (3,100-13,600)	14,500 (3,100-18,400)	9,000 (3,100-12,000)	12,000 (3,100-13,600)	14,500 (3,100-18,400)	
	Heating		12,000 (3,100-22,000)	16,000 (3,100-22,100)	18,000 (3,100-23,900)	12,000 (3,100-22,000)	16,000 (3,100-22,100)	18,000 (3,100-23,900)	
Input Power	Cooling / Heating		0.50 / 0.66	0.79 / 1.01	1.04 / 1.15	0.50 / 0.66	0.79 / 1.01	1.04 / 1.15	
EER	Cooling	BTU/hW	18	15.2	13.9	18	15.2	13.9	
COP	Heating		18.2	15.8	15.7	18.2	15.8	15.7	
SEER	Cooling		33.1	29.4	25.3	33.1	29.4	25.3	
HSPF	Heating		14.2	14	13.4	14	13.8	13.3	
Running Current	Cooling / Heating		2.5 / 3.3	3.8 / 4.7	4.8 / 5.2	2.5 / 3.3	3.8 / 4.7	4.8 / 5.2	
Max Operating Current			10.9	10.9	13.4	11.9	11.9	14.4	
Max. Circuit Breaker			15	15	20	15	15	20	
Airflow Rate	Indoor	Hi / Me / Lo / Qu	CFM (m3/h)	542 / 406 / 312 / 206 (920 / 690 / 530 / 350)	542 / 406 / 312 / 206 (920 / 690 / 530 / 350)	583 / 459 / 312 / 241 (996 / 780 / 530 / 410)	542 / 406 / 312 / 206 (920 / 690 / 530 / 350)	542 / 406 / 312 / 206 (920 / 690 / 530 / 350)	583 / 459 / 312 / 241 (990 / 780 / 530 / 410)
	Outdoor			1,089 / 1,089 (1,850 / 1,850)	1,171 / 1,089 (1,990 / 1,850)	1,218 / 1,348 (2,070 / 2,290)	1,089 / 1,089 (1,850 / 1,850)	1,171 / 1,089 (1,990 / 1,850)	1,218 / 1,348 (2,070 / 2,290)
Sound Pressure	Indoor	Cooling	dB(A)	43 / 37 / 31 / 23	43 / 37 / 31 / 23	45 / 40 / 32 / 26	43 / 37 / 31 / 23	43 / 37 / 31 / 23	45 / 40 / 32 / 26
		Heating		43 / 36 / 31 / 23	43 / 36 / 31 / 23	45 / 39 / 32 / 26	43 / 36 / 31 / 23	43 / 36 / 31 / 23	45 / 39 / 32 / 26
	Outdoor (Cooling/Heating)			46 / 47	47 / 47	49 / 50	46 / 47	47 / 47	49 / 50
Net Dimensions (H X W X D)	Indoor	in. (mm)	11-1/16 x 38-9/16 x 9-7/16 (280 x 980 x 240)			11-1/16 x 38-9/16 x 9-7/16 (280 x 980 x 240)			
	Outdoor		24-7/8 x 31-7/16 x 11-7/16 (632 x 799 x 290)			24-7/8 x 31-7/16 x 11-7/16 (632 x 799 x 290)			
Net Weight	Indoor	lbs (kg)	28 (12.5)			28 (12.5)			
	Outdoor		84 (38)	84 (38)	86 (39)	86 (39)	86 (39)	88 (40)	
Connection Method			Flare			Flare			
Piping Connection	Liquid / Gas	in. (mm)	1/4 / 3/8 (6.35 / 9.52)	1/4 / 3/8 (6.35 / 9.52)	1/4 / 1/2 (6.35 / 12.70)	1/4 / 3/8 (6.35 / 9.52)	1/4 / 3/8 (6.35 / 9.52)	1/4 / 1/2 (6.35 / 12.70)	
Max. Pipe Length Pre-Charge	ft. (m)		66 (20) / 46 (15)			66 (20) / 49 (15)			
Max. Height Difference	ft. (m)		49 (15)			49 (15)			
Moisture Removal	pints/h (L/h)		2.5 (1.2)	2.7 (1.3)	4 (1.9)	2.5 (1.2)	2.7 (1.3)	4 (1.9)	
Operation Range	Outdoor	Cooling	14-115 (-10-46)			14-115 (-10-46)			
		Heating	-5-75 (-21-46)			-15-75 (-26-46)			
Refrigerant			R410A			R410A			

DIMENSIONS

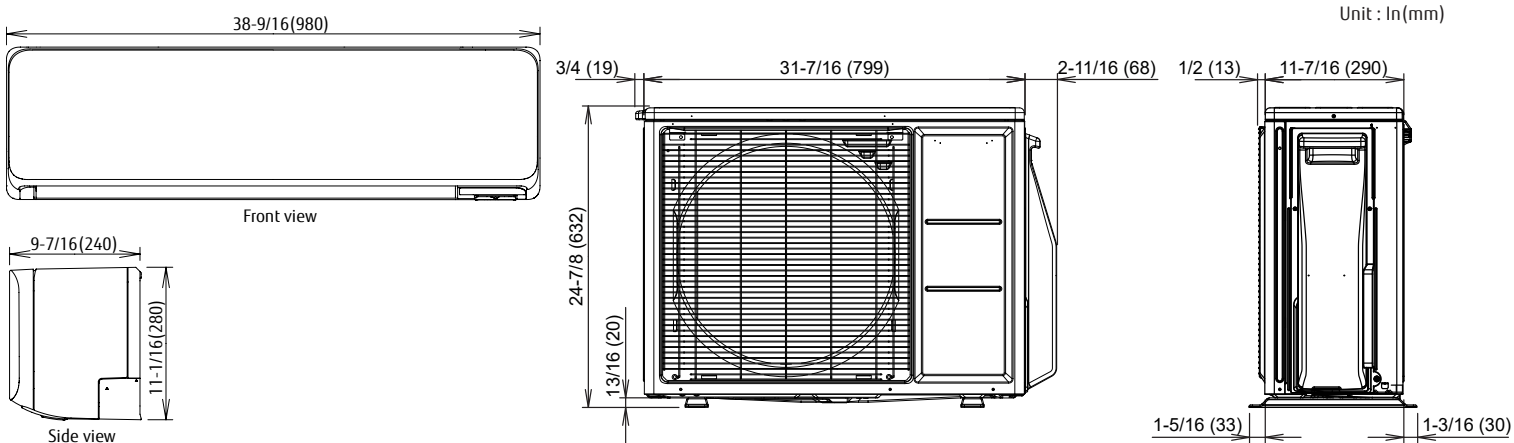

Part # 6-36-FG8054
1/2020

The Fujitsu logo is a registered trademark of Fujitsu Limited. *Halcyon* is a worldwide trademark of FUJITSU GENERAL LIMITED and is a registered trademark of Japan, the USA, and other countries or areas. *FG Air* is a worldwide trademark of FUJITSU GENERAL LIMITED. Other company and product names mentioned herein may be registered trademarks, trademarks or trade names of their respective owners. Specifications and design are subject to change without notice for future improvement. Actual products colors may be different from the colors shown in this printed material.

FUJITSU GENERAL AMERICA, INC.
www.fujitsugeneral.com

FUJITSU